

安心、安定、安全な長寿命製品で社会に貢献する  
Contribute to society with a safe, stable, long-life products

 日本ハードウェア株式会社  
JAPAN HARDWARE CO., LTD.



Divilo™

割型金型

Segmented dies nib

- Divilo™ 概要
- 六角割型パンチニブ
- パンチ用バックプレート
- 六角割型アップセットニブ
- 四角割型アップセットニブ
- 5DD (3DD) 多分割ニブ

- Divilo™ Overview
- HEX segmented punch nibs
- Back plates for punch nibs
- HEX segmented upset nibs
- SQ segmented upset nibs
- 5DD(3DD) segmented nibs and others



# 割型金型

Segmented die

金属の鍛造加工に伴う金型の角部に働く集中応力を逃す目的のために開発されたJHW独自の割型金型の総称です。分割されていない従来の金型は集中応力が発生する角部からの早期破損が問題でした。JHWの割型金型Diviloは従来の一体型の金型に比べて10倍以上の寿命を実現いたします。

JHWは40年以上培った割型技術をもとに従来の割型金型により高い付加価値を与える為にさらなる寿命向上ノウハウを注ぎこみました。

It is a collective name of JHW's original segmented die which was developed for the purpose of escaping the concentrated stress acting on the corner part of the die generated in forging of metal. Early breakage from corner where concentrated stress acts was a problem for conventional undivided dies. JHW's Divilo achieves a lifespan more than 10 times longer than a conventional integrated die. Based on segment type technology cultivated for over 40 years, we have added the know-how for further improvement of life to give higher added value to conventional segmented dies.

【六角フランジボルト鍛造時のコーナーにかかる応力】

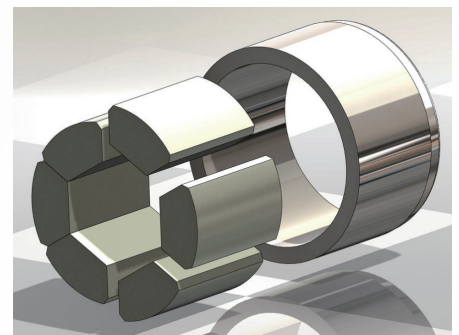
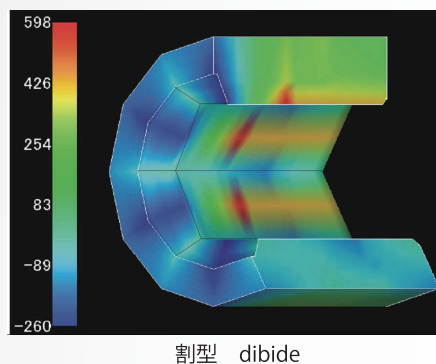
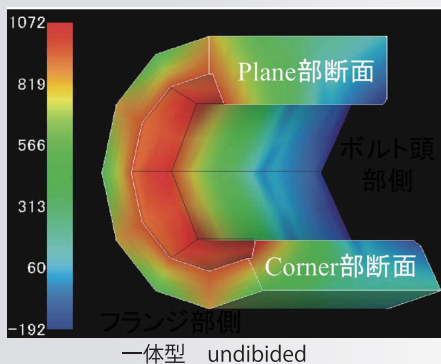

# JHW割型金型の特徴

Characteristics of segmented die

- 集中応力がかかる部分を分割することにより破損を大幅に遅らせることができます。
- 豊富なサイズや規格から選択可能です。
- 寸法指定や追加工指示が可能です。(特注)
- 厳しい基準で高精度に製造されているので、品質のバラつきが少なく安定しています。
- Damage can be greatly delayed by dividing the part subject to concentrated stress.
- You can choose from abundant size and standard products.
- Dimension designation and additional work instructions are available. (Custom order)
- Since it is manufactured with high precision with strict standards, it is stable with less fluctuation of quality.

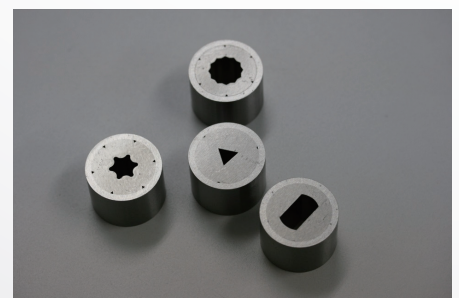
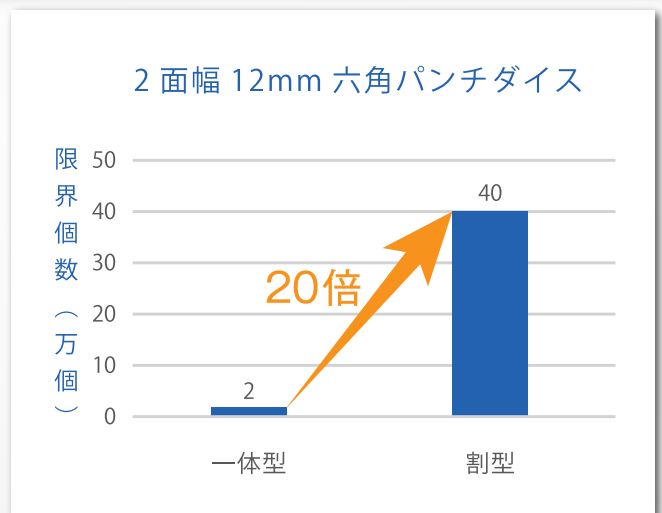

### 標準規格品 Products with standard specifications

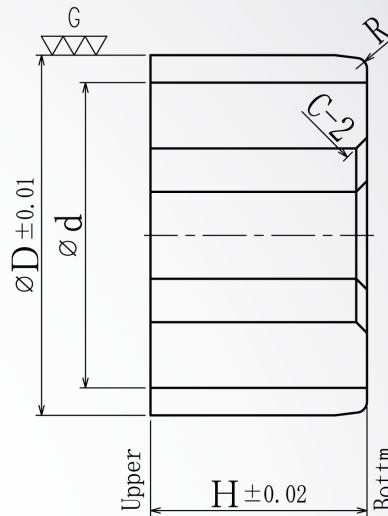
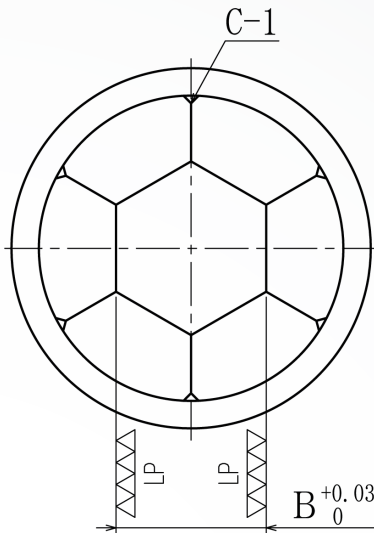

ニブ材質：VC-70相当  
リング材質：SKD61

Nib material : VC-70 equivalent material  
Ring material : SKD61

	製品番号		ニブ寸法					リング寸法	長さ寸法
			B +0.03/-0		φ d	C-1 C-2	フランジ有効径 diameter φ	φ D ± 0.01 (bottom=upper -0.05)	H ± 0.02
	Upper	Bottom(upper-0.02)							
1	DI-P050	483	4.830	4.810	14.15	0.7	11.75	18.80	10
2		486	4.860	4.840					
3	DI-P055	535	5.350	5.330	16.10	0.7	13.70	20.12	10
4		538	5.380	5.360					
5	DI-P060	586	5.860	5.840	16.10	0.7	13.70	20.12	10
6		589	5.890	5.870					
7	DI-P070	686	6.860	6.840	18.11	0.7	15.71	22.13	15
8		689	6.890	6.870					
9	DI-P080	786	7.860	7.840	18.11	0.7	15.71	22.13	15
10		789	7.890	7.870					
11	DI-P100	988	9.880	9.860	20.12	0.7	17.72	25.15	15
12		991	9.910	9.890					
13	DI-P120	1184	11.840	11.820	24.13	1.0	21.13	29.17	15
14		1187	11.870	11.850					
15	DI-P130	1285	12.850	12.830	24.13	1.0	21.13	29.17	20
16		1288	12.880	12.860					
17	DI-P140	1385	13.850	13.830	28.14	1.0	25.14	33.20	20
18		1388	13.880	13.860					
19	DI-P140A	1385	13.850	13.830	32.00	1.0	29.00	37.22	20
20		1388	13.880	13.860					
21	DI-P170	1686	16.860	16.840	32.00	1.0	29.00	37.22	20
22		1689	16.890	16.870					
23	DI-P170A	1686	16.860	16.840	35.18	1.0	32.18	41.24	20
24		1689	16.890	16.870					
25	DI-P190	1882	18.820	18.800	38.19	1.0	35.19	44.26	25
26		1886	18.860	18.840					
27	DI-P220	2184	21.840	21.820	43.22	1.0	40.22	49.30	25
28		2188	21.880	21.860					
29	DI-P240	2384	23.840	23.820	48.24	1.0	45.24	54.33	25
30		2388	23.880	23.860					

- 標準品のお見積、ご注文の際は上記品番にてお問い合わせください。
- オプションとして、座面加工などの追加加工が可能です。
- その他の寸法変更は特注品になります。

- Please refer to the above product numbers when contacting us for estimates or to order standard products.
- We also offer optional flange processing and other additional processing.
- Dimension changes, etc, will require special ordering.

標準規格品 Products with standard specifications

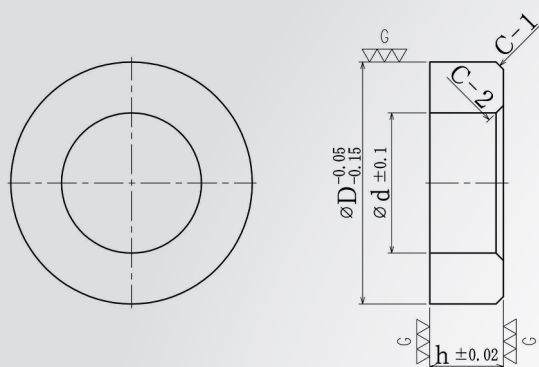

材質：S K D 11(HRC±60)

material : SKD11(HRC±60)

	製品番号	バックライナー寸法				長さ寸法	有効製品番号	
	BP-POOOO	$\phi D_{-0.05/-0.15}$	$\phi d_{\pm 0.1}$	C-1	C-2	$h_{\pm 0.02}$	DI-POOO-OOOO	
1	BP-P050	18.65	6.6	0.7	0.7	5	DI-P050	483 486
2	BP-P055	19.96	7.2	0.7	0.7	5	DI-P055	535 538
3	BP-P060	19.96	8.8	0.7	0.7	5	DI-P060	586 589
4	BP-P070	21.95	10.0	0.7	0.7	7	DI-P070	686 689
5	BP-P080	21.95	11.0	1.0	1.0	7	DI-P080	786 789
6	BP-P100	24.95	14.0	1.0	1.0	7	DI-P100	988 991
7	BP-P120	28.93	16.0	1.0	1.0	7	DI-P120	1184 1187
8	BP-P130	28.93	18.0	1.0	1.0	7	DI-P130	1285 1288
9	BP-P140	32.93	19.0	1.0	1.0	10	DI-P140	1385 1388
10	BP-P140A	36.92	19.0	1.0	1.0	10	DI-P140A	1385 1388
11	BP-P170	36.92	23.5	1.0	1.0	10	DI-P170	1686 1689
12	BP-P170A	40.91	23.5	1.0	1.0	10	DI-P170A	1686 1689
13	BP-P190	43.90	26.0	1.5	1.5	15	DI-P190	1882 1886
14	BP-P220	48.90	29.0	1.5	1.5	15	DI-P220	2184 2188
15	BP-P240	53.89	32.0	1.5	1.5	15	DI-P240	2384 2388

・標準品のお見積、ご注文の際は上記品番にてお問い合わせください。

・上記のバックプレートはDivilo六角パンチニブに準じています。

・Please refer to the above product numbers when contacting us for estimates or to order standard products.

・The above back plate confirm to Divilo punch hex nibs.

### 標準規格品 Products with standard specifications

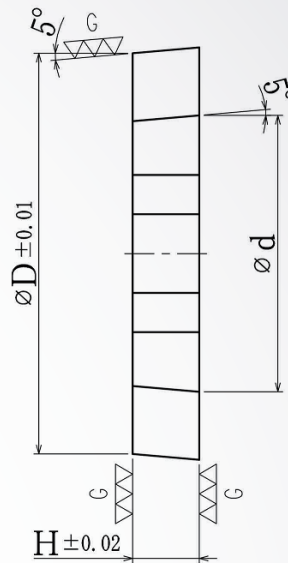
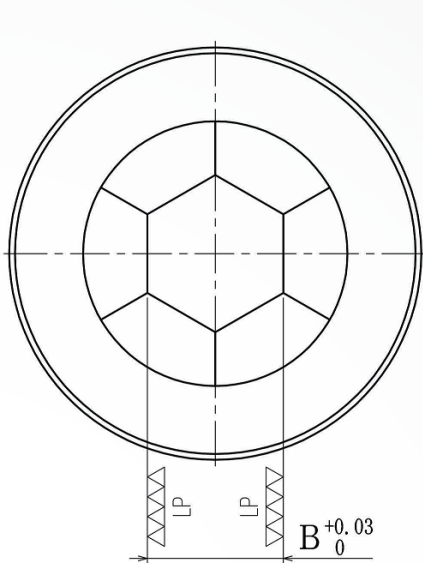

ニブ材質: VC-70  
リング材質: SKD61

Nib material: VC-70 equivalent material  
Ring material: SKD61

	製品番号	ネジ呼び 寸法	ニブ寸法		リング寸法	長さ寸法
	DI-U000-0000		B+0.03/-0	φd	φD±0.01	H±0.02
1	DI-U007	M4	6.86	16.10	23.61	2.68
2	DI-U008	M5	7.86	16.10	23.61	3.38
3	DI-U010-368A	M6	9.86	18.11	29.21	3.68
4	DI-U010-388A					3.88
5	DI-U010-368B	M6	9.86	20.12	29.21	3.68
6	DI-U010-388B					3.88
7	DI-U012-528	M8	11.81	24.13	37.21	5.28
8	DI-U012-538					5.38
9	DI-U013	M8	12.81	24.13	40.81	5.38
10	DI-U014	M10	13.86	28.14	40.81	6.78
11	DI-U017A	M10	16.81	35.18	46.21	6.78
12	DI-U017B	M12	16.81	38.19	46.21	7.8
13	DI-U019	M12	18.81	38.19	56.96	7.78
14	DI-U022	M14	21.75	43.22	60.30	8.78
15	DI-U024	M16	23.75	48.24	65.40	9.78

- 標準品のお見積、ご注文の際は上記品番にてお問い合わせください。
- オプションで口元R, ニブ底部のエア溝等が可能です。
- その他の寸法変更は特注品になります。

- Please refer to the above product numbers when contacting us for estimates or to order standard products.
- We also offer optional round finishing for mouths, nib backside air slotting etc.
- Dimension changes, etc, will require special ordering.

標準規格品 Products with standard specifications

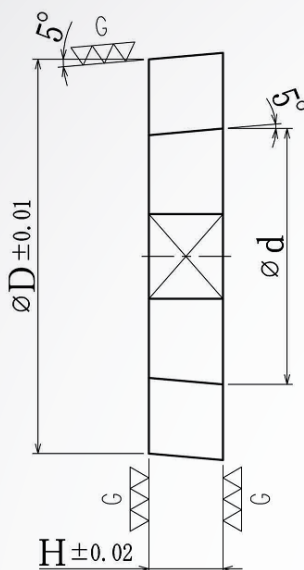
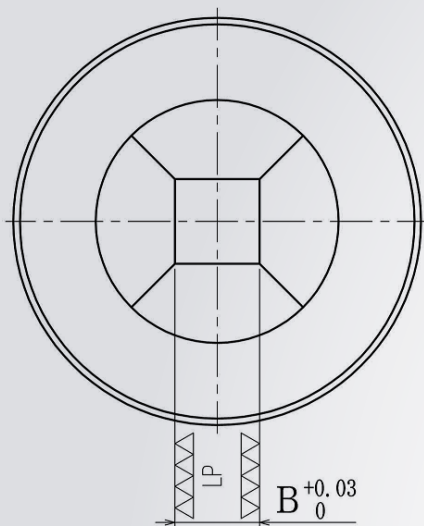

ニブ材質：V C-70相当  
リング材質：S K D61

Nib material : VC-70 equivalent material  
Ring material : SKD61

	製品番号		ネジ呼び 寸法	ニブ寸法		リング寸法	長さ寸法
	DI-S00-00			B+0.03/-0	φd	φD±0.01	H±0.02
1	DI-S5	25	M5	5.00	16.10	23.61	2.5
2		55					5.5
3	DI-S6	30	M6	6.00	18.11	29.21	3.0
4		60					6.0
5	DI-S8	40	M8	8.00	24.13	37.21	4.0
6		70					7.0
7	DI-S10	50	M10	10.00	28.14	40.81	5.0
8		80					8.0
9	DI-S12	60	M12	12.00	32.00	46.21	6.0
10		90					9.0
11	DI-S16	80	M16	16.00	35.18	46.21	8.0
12		100					10.0

•標準品のお見積、ご注文の際は上記品番にてお問い合わせください。

•オプションで口元R、ニブ底部のエア溝等が可能です。

•その他の寸法変更は特注品になります。

•Please refer to the above product numbers when contacting us for estimates or to order standard products.

•We also offer optional round finishing for mouths, nib backside air slotting etc.

•Dimension changes, etc, will require special ordering.

【Option Examples】

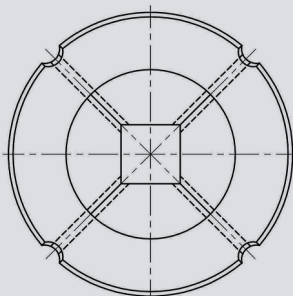

- ニブ裏エア溝加工、ニブ外径エア溝加工
- Backside air slotting

標準規格品 Products with standard specifications

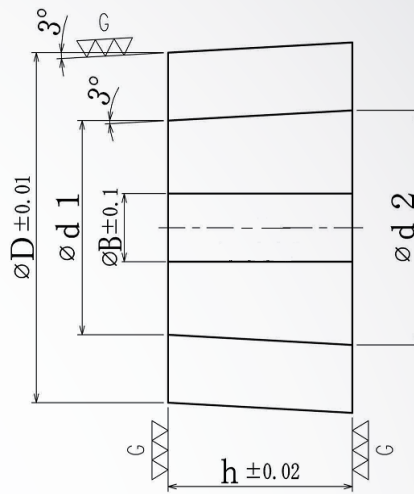
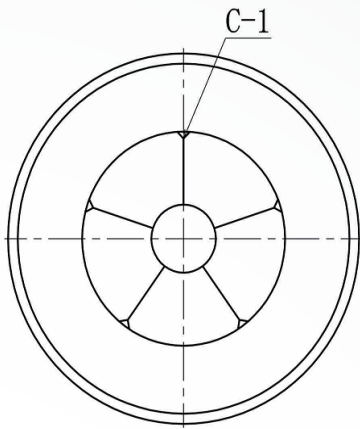

ニブ材質: VC-70相当  
リング材質: S K D61  
内径黒皮仕上げ

Nib material : VC-70 equivalent material  
Ring material : SKD61  
Inner diameter is not finishing

\*5分割か3分割か選択できます。  
\*Both 3DD and 5DD options available

	製品番号 DI-(5 or 3)D-OOOO	ニブ寸法				リング寸法	長さ寸法
		$\phi d 1$	Effective diameter $\phi$	$\phi d 2$	$\phi B \pm 0.1$	$\phi D \pm 0.01$	$h \pm 0.02$
1	DI-OD-1815	16.54	14.04	18.11	3.5	27.00	15
2	DI-OD-1820	16.01	13.51	18.11	3.5	27.00	20
3	DI-OD-2015	18.55	16.05	20.12	3.5	30.00	15
4	DI-OD-2020	18.02	15.52	20.12	3.5	30.00	20
5	DI-OD-2215	22.56	20.06	24.13	4.8	33.00	15
6	DI-OD-2220	22.03	19.53	24.13	4.8	33.00	20
7	DI-OD-2415	22.56	20.06	24.13	4.8	36.00	15
8	DI-OD-2420	22.03	19.53	24.13	4.8	36.00	20
9	DI-OD-2815	26.57	24.07	28.14	5.2	42.00	15
10	DI-OD-2820	26.04	23.54	28.14	5.2	42.00	20
11	DI-OD-3215	30.43	27.93	32.00	7.0	48.00	15
12	DI-OD-3220	29.90	27.40	32.00	7.0	48.00	20

- 標準品のお見積、ご注文の際は上記品番にてお問い合わせください。
- オプションで各種追加加工が可能です。
- その他の寸法変更は特注品になります。

- Please refer to the above product numbers when contacting us for estimates or to order standard products.
- Dimension changes, etc, will require special ordering.
- Dimension changes, etc, will require special ordering.

その他の分割ニブ

Other segmented nibs

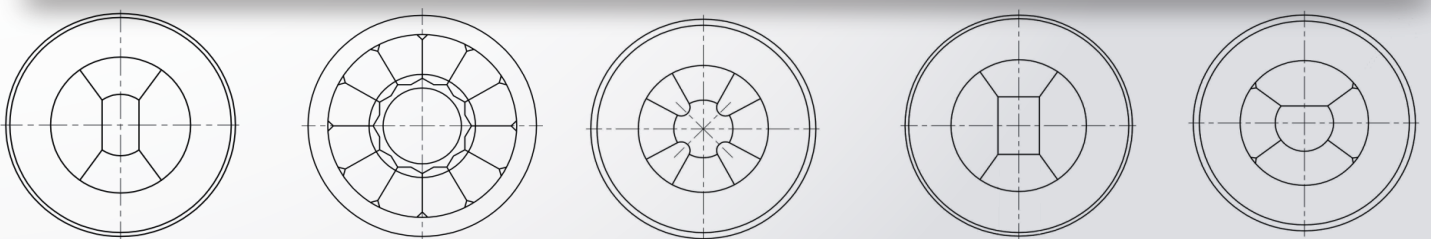

- 標準品以外の分割ニブはご相談下さい。
- サイズや種類によっては分割できない物もあります。

- For non-standard split nibs, please contact us.
- Some cannot be segmented due to their or type.



[www.jhw.co.jp](http://www.jhw.co.jp)

E-mail: [info@jhw.co.jp](mailto:info@jhw.co.jp)

## 日本ハードウェア株式会社

本社 〒457-0863 愛知県名古屋市南区豊二丁目41番21号  
本社工場 Tel.052-698-3666(代) Fax.052-698-3660

鹿児島工場 〒899-7306 鹿児島県曽於郡大崎町永吉5875番地  
鹿児島営業所 Tel.099-476-1555(代) Fax.099-476-0817

## JAPAN HARDWARE CO.,LTD.

### ■ Head office and plant

41-21,Yutaka 2-chome, Minami-ku, Nagoya, Aichi, 457-0863, JAPAN  
Tel.:+81-52-698-3666 Fax.:+81-52-698-3660

### ■ Kagoshima plant

5875, Nagayoshi, Ohsaki-cho, Soo-gun, Kagoshima, 899-7306, JAPAN  
Tel.:+81-99-476-1555 Fax.:+81-99-476-0817